

the **new** world of  
advanced packaging

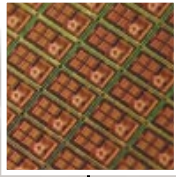

## DS9000CC IC Sorting

# Wafer to Frame Sorting at 8000 UPH

The Laurier DS9000CC system is an optimized platform for sorting 300mm or smaller wafers to tape frame. Automatically sort up to 25 bins with vision inspection and die track mapping.

- Pick & place at up to 8000 devices per hour
- Sort 300 mm and smaller wafers to 300 mm or smaller output tape frames
- Fully automatic cassette to cassette operation
- Placement accuracy of +/- 50  $\mu\text{m}$
- Vision inspection before picking and after placement
- Die size capable from 0.5 mm - 32 mm and as thin as 50  $\mu\text{m}$
- Electronic map import
- Die track mapping of output frames
- Optional placement to waffle packs or Gel-Paks
- Windows<sup>®</sup> XP



— member of Besi group —



Laurier

the **new** world of  
advanced packaging



## Die Sorter

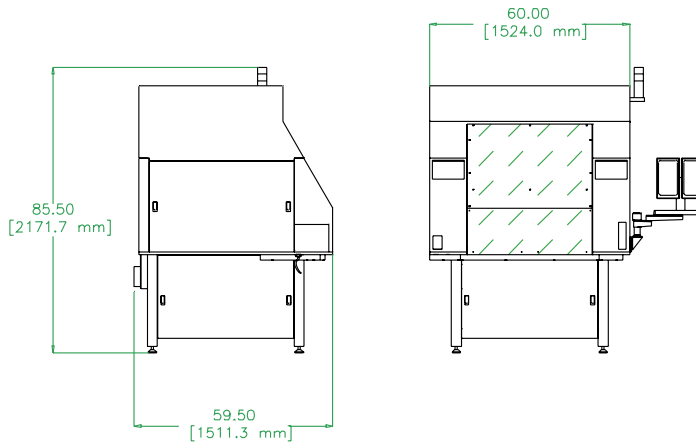

### Technical Specifications DS9000CC

#### Mapping

Row /column and array formats  
SECS II  
ALPs

#### Throughput\*

8,000 UPH sprint rate  
7,500 UPH typical for die < 5mm  
7,000 typical for die > 5mm

#### Inspection

Edge chip detection  
2D Bump  
Place position X, Y, Ø

#### Placement Accuracy

+/- 50 µm @ 3 sigma  
+/- 1 degree theta

#### Die Size

0.5mm to 5mm  
5mm to 32mm

#### Cassette Input

25 slot, 3/16 inch pitch  
Frames 12 & 8 inch

#### Cassette Output

25 slot, 3/16 inch pitch  
Frames 8 & 12 inch  
Carrier plates for waffle packs 2, 3 & 4 inch

#### Electrical

208/220/230/430 VAC single phase  
3KVA

#### Network

Ethernet or SECS  
TCP/IP  
RS232

#### Pneumatic

5.8-7.5 Bar (85 to 120 PSI) Clean Dry Air  
140 L / minute (5 SCFM)

#### Weight

1500 kg (3300lbs.)

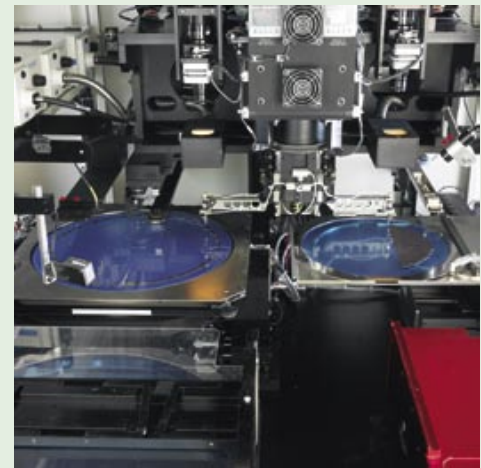

\*Application Dependent

#### SALES OFFICES AND AGENTS

USA Headquarters: Laurier, Inc. Tel: +1 603 206 4800, Email: sales@laurierinc.com ■ Singapore: Besi Singapore Pte. Ltd., Tel: +65-67430-600, E-mail: info.dcap@datacon.at ■ Philippines: Datacon Philippines, Inc., Tel: +63 2 772 40-4243, E-Mail: aramis.inocando@datacon.at ■ Taiwan: Besi Singapore Pte. Ltd. / Taiwan Branch Tel: +886 3 515 3488, E-Mail: eric.kuo@datacon.at ■ South Korea: Datacon Korea Ltd. Tel: +82 2 449 5725, E-Mail: jk.park@datacon.at ■ China: Besi Shanghai R.O. Tel: +86 21 6272 1547, E-mail: hong-hai.shu@datacon.at ■ Thailand and Malaysia: Datacon Asia Pacific Pte. Ltd. Tel: +6012-4112255, E-Mail: lee.mj@datacon.at ■ Europe: Datacon Technology GmbH, Tel.: +43-5337-600-230, email: thomas.leitner@datacon.at

#### Laurier Inc.

10 Tinker Avenue, Londonderry, New Hampshire 03053 USA  
Tel: (603) 206-4800 ■ Fax: (603) 626-4242 ■ sales@laurierinc.com ■ www.laurierinc.com

Laurier, Inc. is a Product Division of BE Semiconductor Industries N.V., (BESI).  
Website: www.besi.com

member of Besi group



# Laurier